

Introduction & Features

The FC-CH21 will program your Chrysler / Dodge / Jeep radio to allow the addition of a reverse camera and VES input if the vehicle is not equipped with these features from the factory (reverse camera and video source sold separately). The FC-CH21 will also allow the factory navigation features of your radio to be used by the passenger at anytime. The interface can also be configured via PC to add even more features, such as: Blind Spot Cameras, Front Camera, and three programmable 12v outputs. The FC-CH21 also has on-demand activation of rear or front camera.

Important Notes

1. It is very important to follow the exact sequence of installation steps as listed in the installation section. Failure to do so will result in the interface not working as intended.
2. If you change the DIP switch settings, you must disconnect and reconnect power for the change to take effect.
3. If you wish to use the blind spot camera, front camera, or programmable outputs 2 & 3, you must use the PAC app to activate them. See page 6 for more details on the PAC app.
4. The navigation unlock feature must be activated every time the key is cycled.
5. If you are streaming audio and activate the navigation unlock, the audio will pause during this process and resume when the radio returns to the audio screen.
6. The VS41 video switcher, AVS21 A/V switcher, or any other universal video switcher must be used in order to use more than one video source with the FC-CH21.
7. If the vehicle is equipped with an external VES Player, the RCAs labeled "Audio/Video To Head Unit" will not allow an additional input to the head unit. You must use the factory A/V input located in the rear of the vehicle.
8. In order to see the text generated by the FC-CH21 on the multi-function display (MFD), it must be set to display audio text.

Module Layout

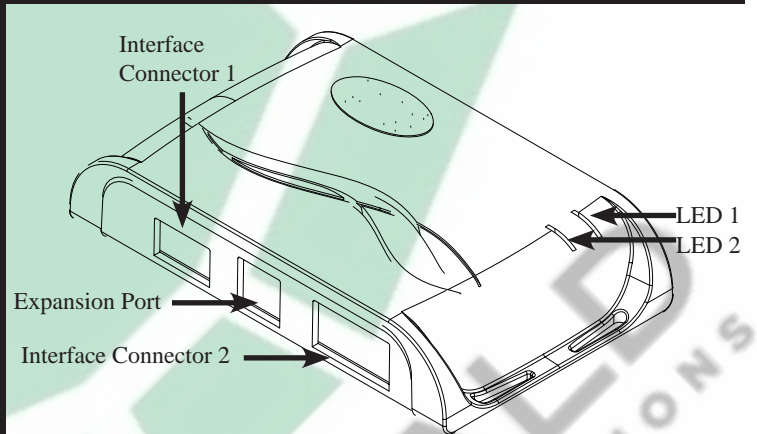
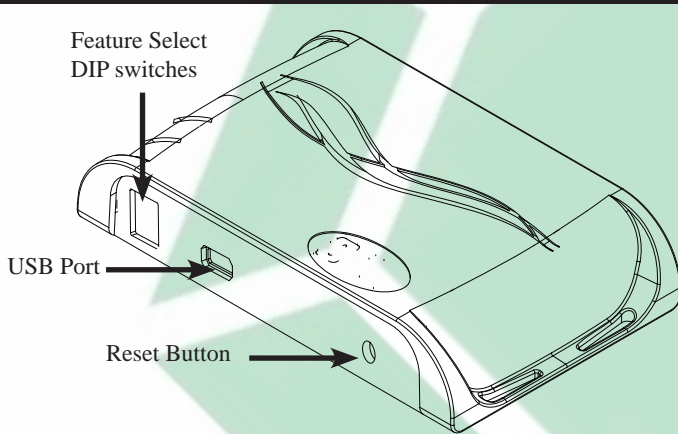

Installation Steps

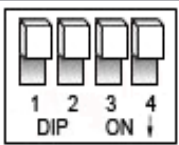

Set DIP switches to the ON position to activate the corresponding features.
Set DIP switches to the OFF position for any features that are not desired.



Reverse Camera	Navigation Unlock	VES Activation	Not Used
1	2	3	4

1. Set DIP switches to the ON position that correspond with the features you want to add. Feature DIP switches must be set before connecting the interface to the vehicle harness.
2. At this point, you can plug the FC into a Windows PC and set up the blind spot cameras, front camera, or the programmable outputs using the PAC app. See page 6 for more details on the PAC app.
3. Depending on the vehicle you are installing the FC-CH21 into, you may need to cut the white / red loop in the harness. Please refer to Fig. B on the next page to see if you need to cut the loop. If your vehicle is listed, cut the loop. If not, do not cut the loop. Please see the Troubleshooting section on page 7 for further explanation of the loop and its purpose.
4. Remove the factory radio and disconnect the factory harness(es).
5. Connect the factory harness(es) into the female connectors on the FC-CH21 harnesses.
6. Connect the aftermarket reverse camera's video output to the female yellow RCA located on the radio side of the FC-CH21-AUX harness. If you are also adding blind spot and / or a front camera, the VS41 can be used (sold separately) in conjunction with the BCI. See page 3 for VS41 wiring. You can also use any universal video switcher and utilize the programmable outputs to trigger as necessary.

Installation Steps (cont.)

Fig A

Wire	Color	Function	Note
Prog. Output 1	Blue	12v+	10 Amp positive output when user programmed feature is activated
Prog. Output 2	Blue / White	12v+	1 Amp positive output when user programmed feature is activated
Prog. Output 3	Blue / Red	12v+	1 Amp positive output when user programmed feature is activated

Fig B

Cut Red / White Loop in These Vehicles		
Make	Model	Year
Chrysler	200	2011-2014
Chrysler	300	2008-2010
Chrysler	Sebring	2008-2010
Dodge	Avenger	2008-2013
Dodge	Caliber	2010-2012
Dodge	Challenger	2008-2014
Dodge	Charger	2008-2010
Dodge	Dakota	2008-2010
Dodge	Durango	2008-2009
Jeep	Commander	2008-2010
Jeep	Compass	2009-2013
Jeep	Grand Cherokee	2008-2010
Jeep	Liberty	2008-2013
Jeep	Patriot	2008-2015

- Connect the trigger wire(s) as needed. Please see Fig. A for trigger wire colors and functions.
- If you wish to use the on-demand activation feature, run and mount the toggle switch on the FC-CH21 harness to the desired location. **PLEASE NOTE:** If you are not adding a front camera, the on-demand switch will only function when triggered one way.
- If you wish to use the forced reverse camera / on-demand feature on any of the vehicles listed in Fig. C, and the vehicle is equipped with a factory reverse camera, you may need to use programmable output 1 (10A, set to "Accessory" by default) to power up the factory reverse camera. To do this a wire must be ran from the FC-CH21 harness to the factory power wire for the reverse camera. The location of this wire will vary depending upon which vehicle you are installing the FC-CH21 into. See below for the different locations. **Please Note:** If the customer does not wish to use the forced reverse camera / on-demand activation feature, or the reverse camera image is present when using these features, you do not have to locate and connect this wire.
- If you are adding an additional A/V input: Connect the A/V outputs from the source to the A/V inputs on the radio side of the FC-CH21-AUX harness. If you have more than one source, the AVS21 or any other universal video switcher must be used (sold separately).
- Connect the FC-CH21 harness to the back of the factory radio.
- If adding reverse camera or additional A/V inputs, connect the FC-CH21-AUX harness to the back of the factory radio. If your vehicle was not equipped with a factory reverse camera, there will most likely be nothing connected to the vehicle side of this harness.
- Turn the ignition to the on position.
- Plug the 4-pin and 20-pin plugs on the FC-CH21 harness into interface connector 1 and 2.
- Both LEDs will blink green while the module is initializing. Once initialized, LED1 will turn solid red and LED2 will begin blinking green. If LED2 blinks red, there is a problem with the data connection to the factory radio. In this case please refer to the troubleshooting section on page 6.
- Turn the vehicle off, shut the doors and lock the vehicle with the factory keyfob. Wait 10 minutes. After 10 minutes, turn vehicle back on and test FC operation (see operation section on page 5).

Fig C

Power Up Factory Reverse Camera		
Make	Model	Year
Dodge	Caravan	2010-2015
Dodge	Journey	2009-2010
Chrysler	Town & Country	2008-2015
Volkswagen	Routan	2009-2013

Reverse Camera Wire Location - Caravan / Town & Country / Routan

- You will need to locate the reverse camera wire in the rear harness located above the rear door trim panel (Fig D).
- The reverse camera wire is the White / Green wire (test with a DMM to verify 12v when the vehicle is shifted into reverse) (Fig E).
- Connect programmable output 1 (10A, set to "Accessory" by default) from the FC-CH21 harness to the White / Green wire using a diode (Fig F). The diode is needed to prevent the reverse lights from coming on when the reverse camera is activated.
- Verify that the reverse lights do not come on when the forced reverse camera / on-demand feature is activated.

Fig D



Fig E

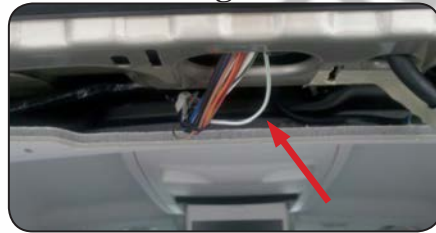
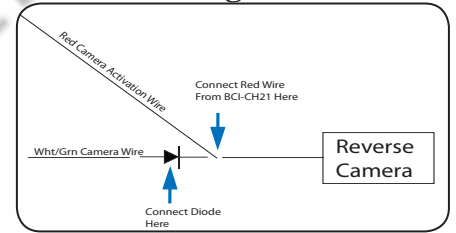

Fig F



Installation Steps (cont.)

Reverse Camera Wire Location - Journey

1. You will need to locate the reverse camera wire in the reverse camera harness located in the liftgate. (Fig A).
2. The reverse camera wire is the White / Green wire (test with a DMM to verify 12v when the vehicle is shifted into reverse) (Fig B).
3. Connect programmable output 1 (10A, set to "Accessory" by default) from the FC-CH21 harness to the White / Green wire using a diode (Fig C). The diode is needed to prevent the reverse lights from coming on when the reverse camera is activated.
4. Verify that the reverse lights do not come on when the forced reverse camera / on-demand feature is activated.

Fig A



Fig B

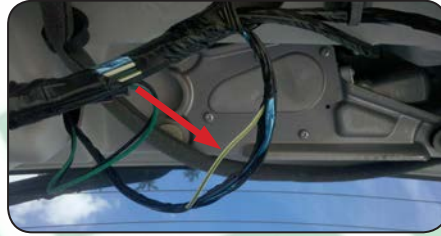
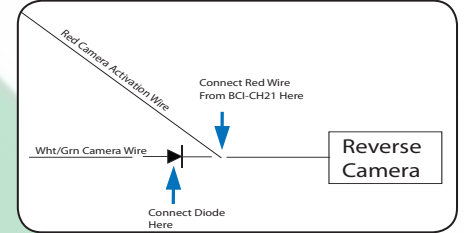

Fig C



Connecting a VS41 (sold separately)

PLEASE NOTE: In order for the interface to support a VS41, the FC must be programmed with firmware version 6 or higher.

If you are adding a front camera and two blind spot cameras, or any combination of the three, to the factory radio, a VS41 (sold separately) can be used in conjunction with the FC. Follow the example below to make all inputs work accordingly through the one camera input on the factory radio. Connect the 10-pin harness from the VS41 harness into the Expansion Port on the FC-CH21. Do not manually wire the trigger wires, or power and ground leads, when using the Expansion Port connector. When the appropriate CAN-Bus signals are detected (ie. reverse, or turn signal) the corresponding camera input will be automatically selected, and it's video feed will be routed to the factory radio display.

The behaviors of the cameras and output wires can be configured using the PAC app. Please see page 6 for full details on using the PAC app.

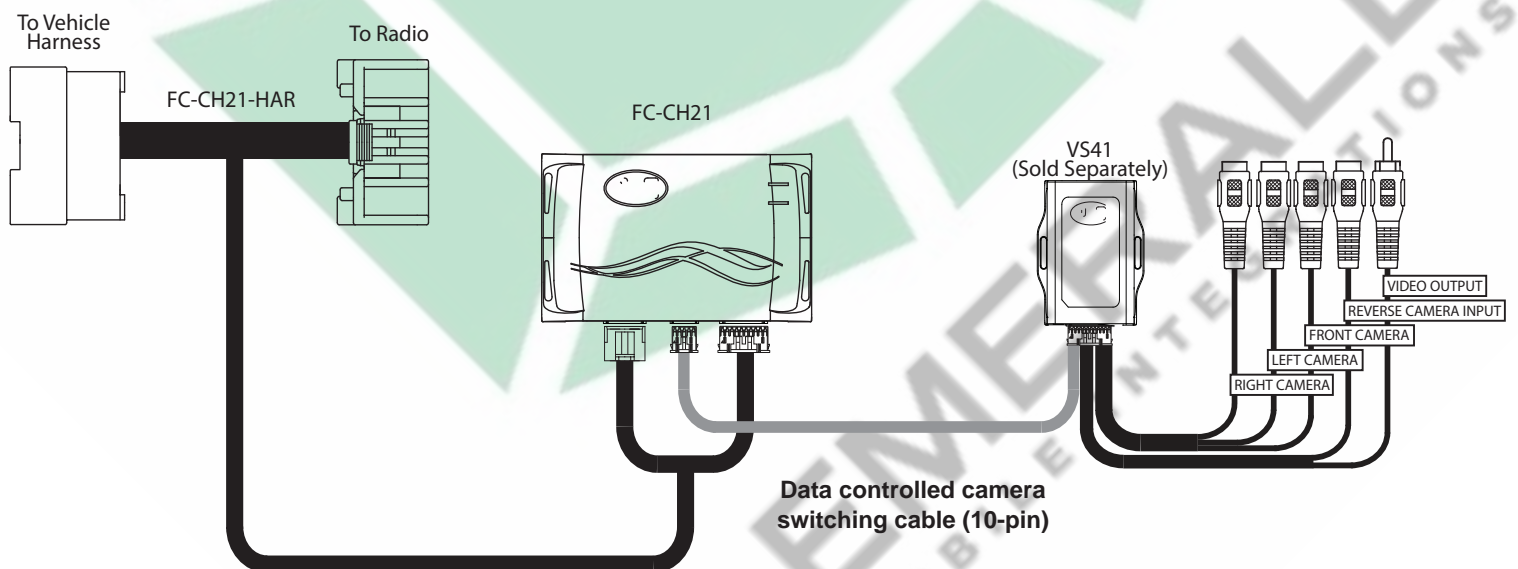

Common Use Examples w/Setup

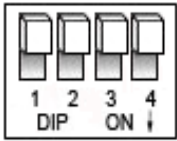

Set DIP switches to the ON position to activate the corresponding features.
Set DIP switches to the OFF position for any features that are not desired.



Reverse Camera	Navigation Unlock	VES Activation	Not Used
1	2	3	4

Adding Reverse Camera Only

- **DIP switch 1** = ON
- **DIP switch 2** = OFF
- **DIP switch 3** = OFF
- No additional programming needed as Programmable Output 1 (10A) is set to "Accessory" by default (use to power cameras)
- Need to use FC-CH21-AUX Harness (included)

Adding Reverse Camera and Navigation Unlock

- **DIP switch 1** = ON
- **DIP switch 2** = ON
- **DIP switch 3** = OFF
- No additional programming needed as Programmable Output 1 (10A) is set to "Accessory" by default (use to power camera)
- Need to use FC-CH21-AUX Harness (included)

Adding Reverse Camera and VES

- **DIP switch 1** = ON
- **DIP switch 2** = User Preference
- **DIP switch 3** = ON
- No additional programming needed as Programmable Output 1 (10A) is set to accessory by default (use to power cameras and video source)
- Need to use FC-CH21-AUX Harness (included)

Adding Reverse Camera and a Bed Camera using the AVS21 (sold separately)

- **DIP switch 1** = ON
- **DIP switch 2** = OFF
- **DIP switch 3** = OFF
- **PC Settings**
 - **Blind Spot Camera** = OFF.
 - **Front Camera** = OFF
 - **Programmable Output 1 (10A)** = Any Camera Active or Accessory (use to power cameras)
 - **Programmable Output 2 (1A)** = Forced Reverse Camera (use to trigger AVS21 when the forced reverse camera feature is triggered via the SWC or the on-demand switch)
 - **Programmable Output 3 (1A)** = OFF
 - Need to use FC-CH21-AUX Harness (included)

Adding Blind Spot Cameras using the VS41 (sold separately)

- **DIP switch 1** = ON if adding rev cam; OFF if already equipped
- **DIP switch 2** = User Preference
- **DIP switch 3** = OFF
- **PC Settings**
 - **Blind Spot Camera** = User Preference, can't be OFF
 - **Front Camera** = Off
 - **Programmable Output 1 (10A)** = Any Camera Active or Accessory (use to power cameras)
 - **Programmable Output 2** = OFF
 - **Programmable Output 3** = OFF
 - Need to use FC-CH21 AUX Harness

Adding Blind Spot Cameras and a Front Camera using the VS41 (sold separately)

- **DIP switch 1** = ON if adding reverse camera; OFF if already equipped
- **DIP switch 2** = User Preference
- **DIP switch 3** = OFF
- **PC Settings**
 - **Blind Spot Camera** = User Preference, can't be OFF.
 - **Front Camera** = User Preference, can't be OFF.
 - **Programmable Output 1 (10A)** = Any Camera Active or Accessory (use to power cameras)
 - **Programmable Output 2 (1A)** = OFF
 - **Programmable Output 3 (1A)** = OFF
 - Need to use FC-CH21-AUX Harness

Adding Reverse Camera, Blind Spot Cameras, and a Front Camera using the VS41 (sold separately), a bed camera using the AVS21 (sold separately), Navigation Unlock, and VES

- **DIP switch 1** = ON
- **DIP switch 2** = ON
- **DIP switch 3** = ON
- **PC Settings**
 - **Blind Spot Camera** = User Preference, can't be OFF.
 - **Front Camera** = User Preference, can't be OFF.
 - **Programmable Output 1 (10A)** = Accessory (use to power cameras and video source)
 - **Programmable Output 2 (1A)** = Forced Reverse Camera (use to trigger AVS21 when the forced reverse camera feature is triggered via the SWC or the on-demand switch)
 - **Programmable Output 3 (1A)** = OFF
 - Need to use FC-CH21-AUX Harness (included)

Operation

Reverse Camera

If you have DIP switch 1 in the ON position, the factory screen will switch to the reverse camera whenever the vehicle is placed into reverse. You can also force the reverse camera at anytime by pressing and holding the center button on the back left side of the steering wheel for at least 4 seconds. If your vehicle does not have SWC on the back of the steering wheel, you can always use the supplied on-demand activation toggle switch to force the reverse camera.

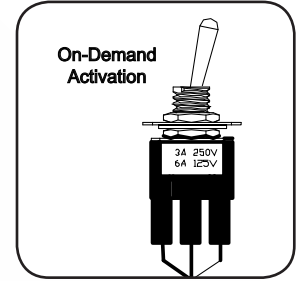
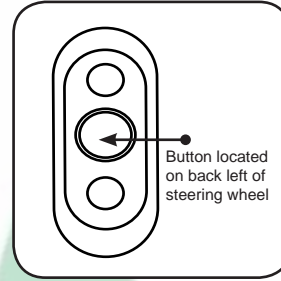

VES Mode

If you have DIP switch 2 in the ON position, it will activate VES mode on the factory radio.

To access VES mode, follow these steps:

1. Press the Media button on the factory radio
2. Press the "VES" icon on the screen
3. Press the "View Video" icon on the screen
4. This will display video and play audio that is fed in through the group of RCAs labeled "Audio/Video To Head Unit" on the FC-CH21-AUX-HAR. **PLEASE NOTE:** If the vehicle is equipped with an external VES Player, the RCAs labeled "Audio/Video To Head Unit" will not allow an additional input to the head unit. You must use the factory A/V aux in located in the rear of the vehicle.
5. If you want to feed more than one A/V source into the VES input, an AVS21 must be used.
6. The group of RCAs labeled "Audio/Video To Rear Screen" on the FC-CH21-AUX-HAR will only output A/V from the internal DVD player. You can not make the radio output video from any other source.
7. If the vehicle is equipped with a factory rear screen, an AVS21 can be used on these RCAs to feed more than one A/V source to the rear screen.

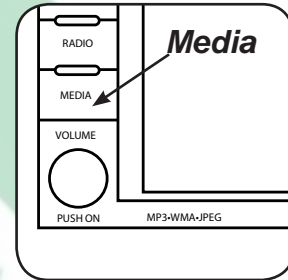

Navigation Unlock

If you have DIP switch 3 turned ON, you can activate the navigation unlock, which will enable any features that are normally locked out while the vehicle is in motion.

To activate the navigation unlock, follow these steps:

1. Press and hold the center button on the back right of the steering wheel for at least two seconds, and then release, to activate the FC-CH21. If the vehicle is not equipped with factory SWC, turn the radio off then on within three seconds by pressing the volume knob on the radio.
2. If the vehicle is equipped with a MFD in the cluster it will display "Confirm Safe Passenger Use". If the vehicle is equipped with an external Uconnect module the radio will display "Press Again to Confirm Safe Passenger Use". If present, the dash mount LED will flash green.
3. Press the "Source" button on the SWC, or turn the radio off then on again within 5 seconds to acknowledge "safe use", agreeing that use will be performed only by the passenger whenever the vehicle is in motion, and activate the FC-CH21.
4. If applicable, the MFD and/or radio will display "Acknowledged". If present, the dash mount LED will then illuminate green.
5. To de-activate the FC-CH21 simply press and hold the "Source" button on the SWC for at least two seconds and then release or turn the radio off then back on again.

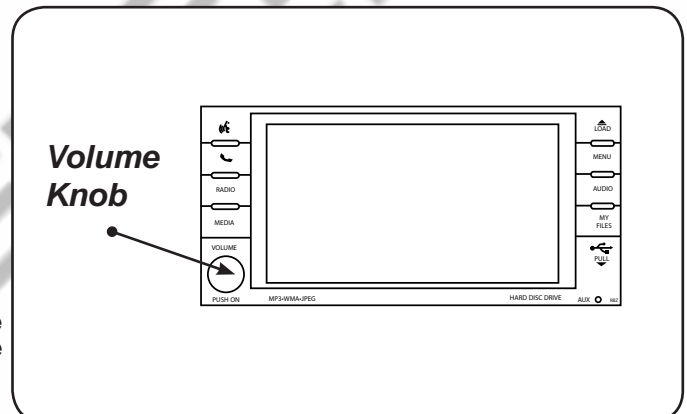
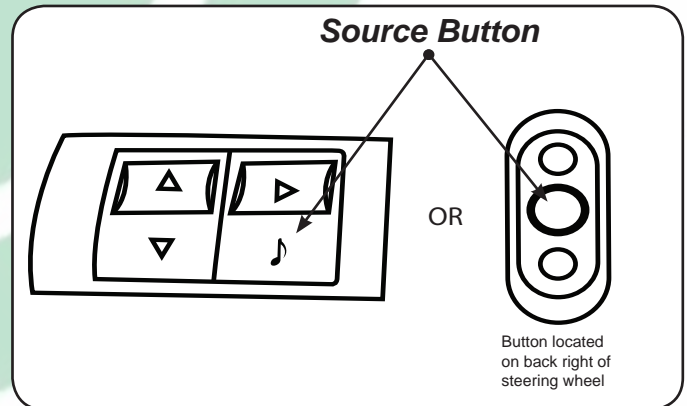

WARNING: In order to avoid distraction, which could lead to an accident, the driver should never utilize systems unlocked by the FC-CH21 when the vehicle is in motion. Even when operated by the passenger, the vehicle driver should maintain their attention on the road at all times.

PAC App

PLEASE NOTE:

The BCI must be programmed with revision 9 or higher to support app programmability. You can program the BCI either on the bench or in the car (with ignition on). To program the BCI module with the PAC app, follow these steps:

1. Download and install the PAC app. It can be found online at www.aampglobal.com/downloads.
2. Once installed, open the app.
3. Connect the interface to the PC.
4. When first connected, the revision info for both the app and the interface should be displayed. Select "Configure". (Fig A).
5. You may now choose between "Camera Settings" and "Interface User Options" on the left, then make selections within those categories on the right (Fig B) Please reference the chart below for all available features and descriptions.
6. Once all selections have been made, you can simply disconnect the interface and install it.

Fig A



Fig B

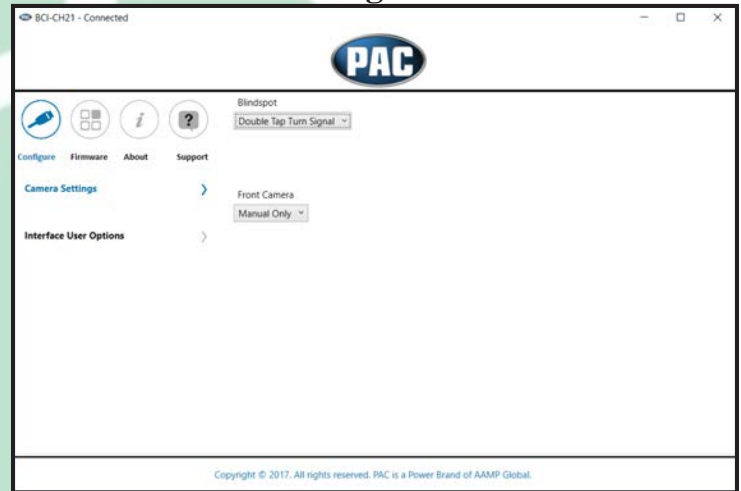

Available FC-CH21 Features

Camera Settings

Feature	Option	Description	Notes
Blind Spot Camera	Double tap turn signal	This will activate the camera input when you double tap the turn signal within 2 seconds.	
	Turn Signal	This will activate the camera input whenever a turn signal is on.	
	Turn signal and moving above xMPH	This will activate the camera input when a turn signal is active and the vehicle is going faster than the designated number.	
Front Cam	Greater than 0MPH and less than xMPH	This will activate the camera input whenever the vehicle is going faster than 0 mph or less than the designated number.	
	Manual Only	This will allow you to activate the camera input manually by using the on-demand activation toggle switch.	
	On when shift into D until 6MPH or 30 seconds	This will activate the camera input whenever the vehicle is placed into Drive. The camera input will turn off once the vehicles MPH is faster than 6MPH, or after 30 seconds.	This mode will not work in vehicles with a manual transmission.
	On when shift out of R until 6 MPH or 30 seconds	This will activate the camera input whenever the vehicle is shifted out of reverse. The camera input will turn off once the vehicles MPH is faster than 6MPH, or after 30 seconds.	This mode should only be used in vehicles that have a manual transmission.

Interface User Options

Prog Out 1	Accessory	This will provide a 12v+ trigger whenever the key is in the accessory or run position.	This is the default setting for Prog Out 1.
	Any Camera Active	This will provide a 12v+ trigger whenever any camera is triggered.	
	Reverse Camera Image	This will provide a 12v+ trigger whenever the vehicle is placed in reverse or the reverse camera is forced on using the SWC or the on-demand activation toggle switch.	
	Reverse Gear	This will provide a 12v+ trigger whenever the vehicle is placed in reverse.	
Prog Out 2 & 3	Accessory	This will provide a 12v+ trigger whenever the key is in the accessory or run position.	
	Driver Blind Spot Camera	This will provide a 12v+ trigger whenever the driver side blind spot camera is activated.	
	Forced Reverse Camera Image	This will provide a 12v+ trigger whenever the reverse camera is forced on using the SWC.	
	Front Camera Active	This will provide a 12v+ trigger whenever the front camera is activated.	
	Passenger Blind Spot Camera	This will provide a 12v+ trigger whenever the passenger side blind spot camera is activated.	
	Reverse Camera image	This will provide a 12v+ trigger whenever the vehicle is placed in reverse or the reverse camera is forced on using the SWC.	
	Reverse Gear	This will provide a 12v+ trigger whenever the vehicle is placed in reverse.	
Off		This is the default setting for Prog Out 2 & 3.	

Troubleshooting

1. Harness Loop - The loop in the FC-CH21-HAR is a CAN termination resistor that needs to be present on certain vehicles. If you have followed the instructions for cutting the loop and your radio is not coming on and the amber LED is blinking, you may need to re-connect or cut the loop (depending on what you did initially).
2. If the vehicle's reverse lights come on when the forced reverse camera feature is engaged, then the diode is not wired properly. Please refer to "Fig. F" on page 2 for proper diode wiring.
3. Cannot hear uConnect or nav voice - Be sure that the 10-pin connector is plugged in behind the radio.
4. If the factory radio does not come on or "flickers" off & on, the factory amplifier does not turn on or you are receiving audio on only one side of the vehicle, please make sure that the male pins in the FC-CH21 plug are not bent or out of place.
5. The module can be reset to factory default settings by pressing and holding the reset button (on the side of the module) for 5 seconds until LED1 begins blinking red. Release the button and both LEDs will blink green indicating the module is initializing.
6. The LEDs on the module can tell you what the FC-CH21 is doing. Please refer to the chart below for LED status patterns and possible troubleshooting actions.

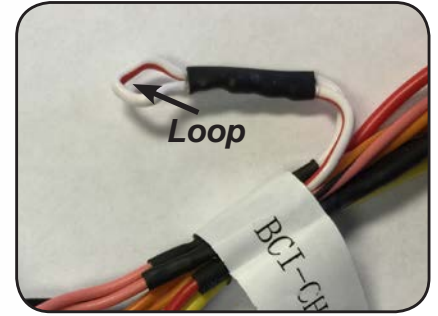

LED Pattern	State	Action
Dual flashing green	Initializing	Turn on ignition Wait for BCI to finish initializing
LED 1 solid green	Active	N/A
LED 2 flashing green	CAN Activity	N/A
LED 1 solid red	Programmable output 1 active	N/A
LED 2 flashing red	No CAN communication	Check harness and connector pins for proper connection or change status of loop (cut or re-connect)
LED 1 flashing red	Resetting	N/A
LED 2 flashing amber	USB connected	N/A

Year(s)	Make	Model	Trim Level				
2011-2014	CHRYSLER	200	ALL TRIM LEVELS	2009-2012	DODGE	RAM TRUCK	ALL TRIM LEVELS
2008-2010	CHRYSLER	300	ALL TRIM LEVELS	2008-2010	JEEP	COMMANDER	ALL TRIM LEVELS
2008-2010	CHRYSLER	SEBRING	ALL TRIM LEVELS	2009-2016	JEEP	COMPASS	ALL TRIM LEVELS
2008-2016	CHRYSLER	TOWN & COUNTRY	ALL TRIM LEVELS	2017	JEEP	COMPASS	CLASSIC
2008-2014	DODGE	AVENGER	ALL TRIM LEVELS	2008-2013	JEEP	GRAND CHEROKEE	ALL TRIM LEVELS
2010-2012	DODGE	CALIBER	ALL TRIM LEVELS	2008-2012	JEEP	LIBERTY	ALL TRIM LEVELS
2008-2014	DODGE	CHALLENGER	ALL TRIM LEVELS	2010-2017	JEEP	PATRIOT	ALL TRIM LEVELS
2008-2010	DODGE	CHARGER	ALL TRIM LEVELS	2007-2017	JEEP	WRANGLER	ALL TRIM LEVELS
2008-2010	DODGE	CHARGER	ALL TRIM LEVELS	2018	JEEP	WRANGLER	JK
2008-2010	DODGE	DAKOTA	ALL TRIM LEVELS	2007-2017	JEEP	WRANGLER UNLIMITED	ALL TRIM LEVELS
2008-2009, 2011-2013	DODGE	DURANGO	ALL TRIM LEVELS	2010-2012	RAM	RAM TRUCK	ALL TRIM LEVELS
2010-2016	DODGE	GRAND CARAVAN	ALL TRIM LEVELS	2009-2013	VOLKSWAGEN	ROUTAN	ALL TRIM LEVELS
2009-2010	DODGE	JOURNEY	ALL TRIM LEVELS				
2008	DODGE	MAGNUM	ALL TRIM LEVELS				
2007-2010	DODGE	NITRO	ALL TRIM LEVELS				

